

VN-Box Winder HT



Axial box fan for smoke exhaust.

The possibilities are extensive and besides the diameter of the impeller and speed, also the fan can be configured by different types of impellers, the angle of the impeller and the motor power.

Sizes	560 up to 1.250 mm
Motor (standard)	HT motor IP55, 400/3/50
Capacity	up to 140.000 m ³ /h
Pressure	up to 1.300 Pa
Control	Frequency converter
Casing	Steel galvanized with sound insulated material
Impeller	Aluminum profiled
Extra	Suitable for high temperatures up to 200°C , 300°C or 400°C for 120 minutes (F200, F300 or F400). The fans are suitable to extract smoke and hot air and are certificated following EN 12101-3:2015
Accessories	Grids / Shutters / Anti-vibration mounts / Mounting feet / Switches / Frequency converter s

2 pole (3.000 rpm.) – 400/3/50

Model	Capacity max. (m3/h)	100 Pa m3/h	200 Pa m3/h	400 Pa m3/h	Pressure max. (Pa stat.)	Motor (kW)	In max. (A)
562/B T	24.600	23.000	22.500	21.000	1.350	5,5	10,6
562/C T	27.970	26.500	26.000	23.000	1.400	7,5	14,2

4 pole (1.500 rpm.) – 400/3/50

Model	Capacity max. (m3/h)	200 Pa m3/h	400 Pa m3/h	600 Pa m3/h	Pressure max. (Pa stat.)	Motor (kW)	In max. (A)
564/B T	12.300	7.900	-	-	330	0,75	1,85
564/C T	14.000	9.200	-	-	350	1,1	2,44
634/B T	17.100	12.000	-	-	350	1,1	2,44
634/C T	18.700	13.500	-	-	340	1,5	3,29
714/B T	19.550	13.000	5.500	-	460	1,5	3,29
714/C T	23.720	18.000	-	-	300	2,2	4,64
804/B T	33.950	28.500	14.500	-	470	4	7,69
804/C T	37.220	32.500	23.500	-	460	5,5	10,6
904/B T	42.210	36.100	24.000	14.400	710	5,5	10,6
904/C T	49.200	42.900	32.800	18.600	735	7,5	14,2
1004/B T	62.600	56.000	48.000	34.000	910	11	21,5
1004/C T	75.500	69.800	62.000	49.500	900	15	29,0
1254/B T	110.950	103.000	91.500	77.000	1000	22	41,7
1254/C T	129.270	121.900	112.400	100.000	920	30	54,8
1254/D T	134.450	129.100	119.600	107.300	920	37	66,8
1254/E T	152.000	145.100	139.000	129.100	850	45	79,9

6 pole (1.000 rpm.) – 400/3/50

Model	Capacity max. (m3/h)	100 Pa m3/h	200 Pa m3/h	400 Pa m3/h	Pressure max. (Pa stat.)	Motor (kW)	In max. (A)
566/B T	8.120	4.600	-	-	150	0,25	0,70
566/C T	9.230	5.500	-	-	160	0,37	1,11
636/B T	11.600	7.100	-	-	160	0,37	1,11
636/C T	12.385	8.400	-	-	150	0,55	1,36
716/B T	12.900	8.000	2.500	-	200	1,5	3,29
716/C T	15.650	11.250	-	-	135	0,75	1,85
806/B T	23.560	19.000	8.000	-	210	1,5	3,29
806/C T	27.290	23.000	14.000	-	200	2,2	4,64
906/B T	27.860	23.000	14.000	-	310	1,5	3,29
906/C T	32.465	27.500	19.800	-	330	2,2	4,64
1006/B T	41.320	36.000	30.000	-	390	3	6,47
1006/C T	45.960	41.000	35.000	18.000	480	4	7,69
1006/D T	49.830	45.000	40.000	-	390	5,5	10,6
1256/A T	61.115	57.000	48.000	25.000	480	5,5	10,6
1256/B T	73.210	69.000	58.000	35.000	600	7,5	14,2
1256/C T	85.320	81.000	72.000	50.000	610	11	21,5

[Types and changes reserved]

Indication dimensions VN-Box Winder HT

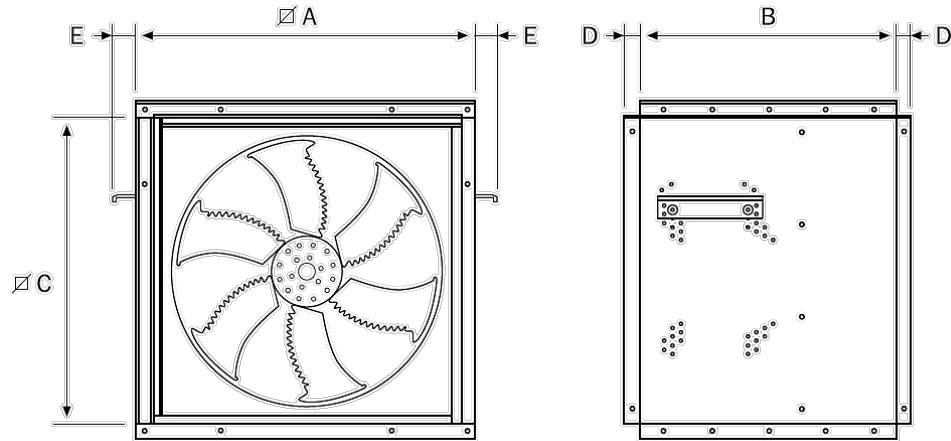

	A	B	C	D	E
560	695	530	630	30	40
630	790	550	725	30	40

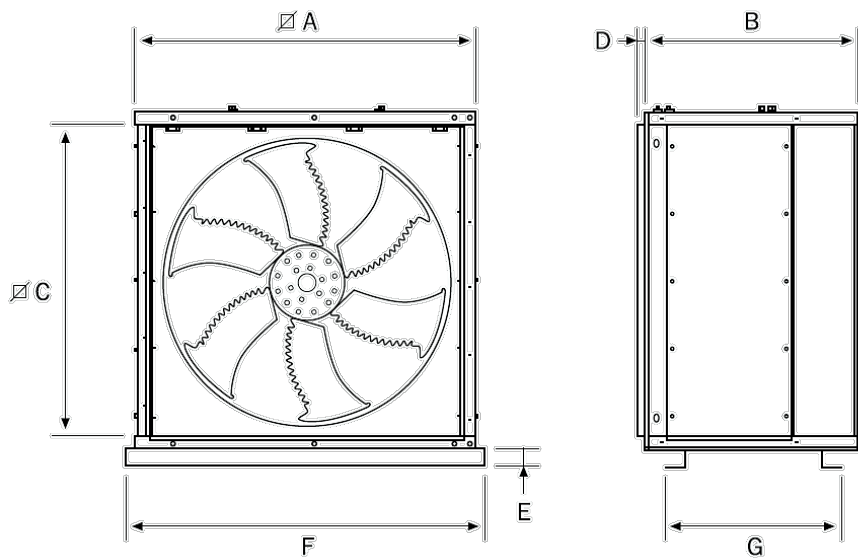

	A	B	C	D	E	F	G
710	873	650	800	30	100	1053	450
800	973	750	850	30	100	1073	545
900	1167	750	970	30	100	1327	500
1000	1200	750	1065	30	100	1327	620
1250	1490	940	1380	30	100	1572	735